

# oxoline

Very high rigidity inserts **1000**



Contents	page
Inhaltsverzeichnis	Seite
Table des matières	page



Presentation of OXOline Vorstellung der OXOline Présentation d'OXOline.....	3
---	---

	K10	BI40	BI40U	TIN
✓	✓	✗	◇	
✓	✓	✗	◇	

Coating of inserts Beschichtung der Wendepplatten Revêtements des plaquettes.....	4
---	---



<b>OXOline 1000 .....</b>	<b>5</b>
---------------------------	----------



Standard fixation Standard Befestigung Fixation standard.....	5
---	---



By behind fixation Befestigung von hinten Fixation par l'arrière .....	7
--	---



<b>OXOline 1100 .....</b>	<b>14</b>
---------------------------	-----------



Standard fixation Standard Fixation standard.....	14
---	----

**Presentation of OXOline**  
**Vorstellung der OXOline**  
**Présentation d'OXOline**

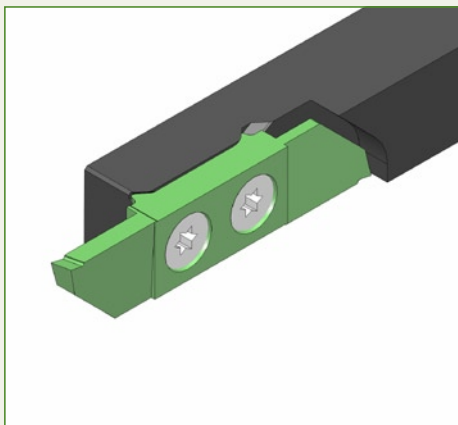
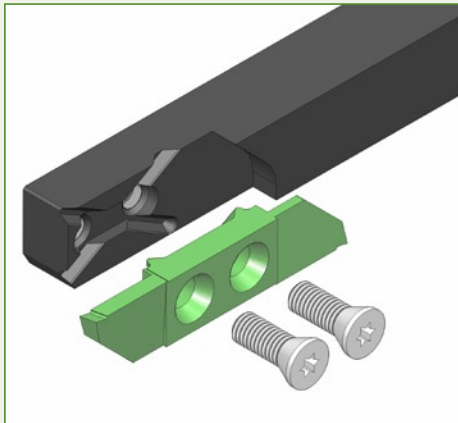

**Advantages of OXOline**

- High rigidity inserts.
- Increase of stability thanks 2 screws fixing system.
- Repetitiveness of the cutting edge  $\pm 0,01$  mm.
- Positioning in all axes.
- The screw is free of all radial stress.
- 2 cutting edges available.

**Vorteile der OXOline Linie**

- Sehr steife Wendepplatten.
- Zunahme der Stabilität dank zweier Schrauben.
- Wiederholbarkeit der Schnittkante  $\pm 0,01$  mm.
- Platzierung in allen Achsen.
- Keine radialen Spannungen.
- 2 verfügbare Schnittkanten.

**Avantages de la ligne OXOline**

- Plaquettes haute rigidité.
- Accroissement de la stabilité grâce aux 2 vis.
- Répétitivité de l'arête de coupe  $\pm 0,01$  mm.
- Positionnement dans tous les axes.
- La vis est libre de toute tension radiale.
- 2 arêtes de coupe.

**Coating of inserts**  
**Beschichtung der Wendepplatten**  
**Revêtement des plaquettes**

Description Beschreibung Désignation	Composition Zusammensetzung Composition
K10	Without coating Ohne Beschichtung Sans revêtement
BI40	TiAlN
BI40U	AlTiN monolayer AlTiN monolage AlTiN monocouche
TIN	TiN

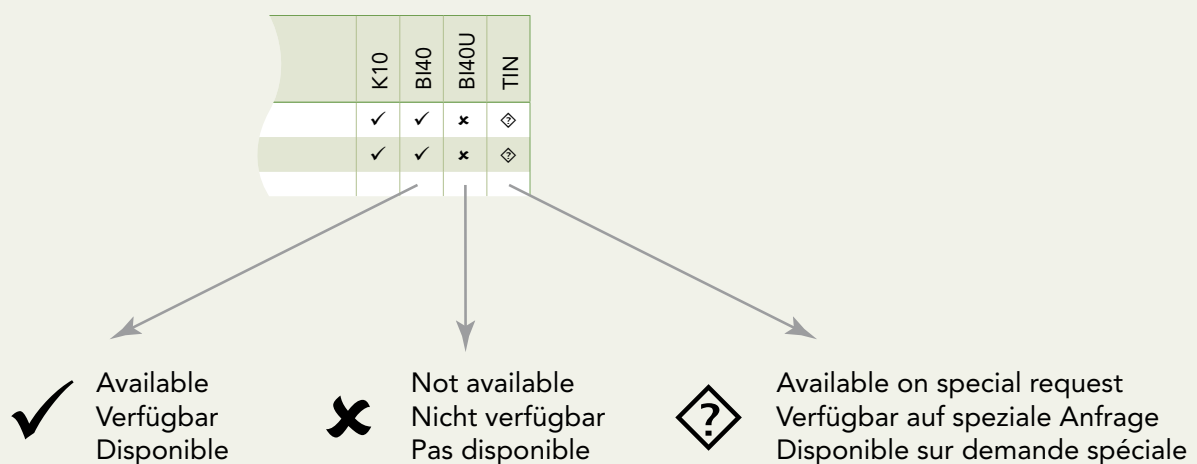

**Field of application of OXOline 1000**  
**Anwendungsbereich von OXOline 1000**  
**Champ d'application d'OXOline 1000**





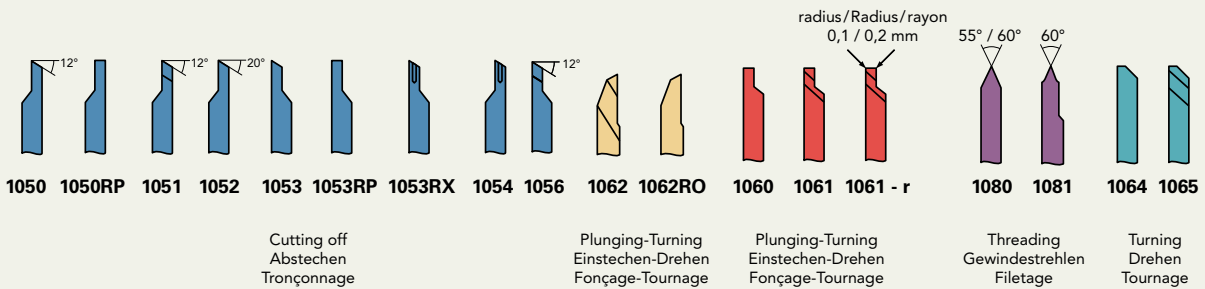
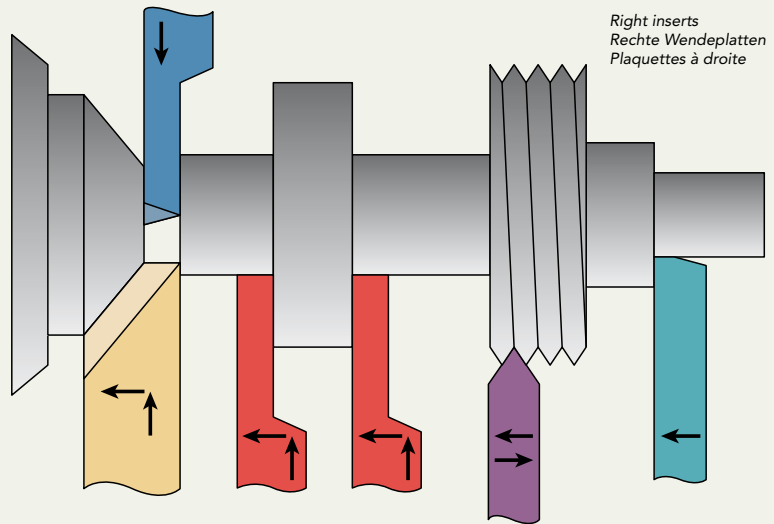

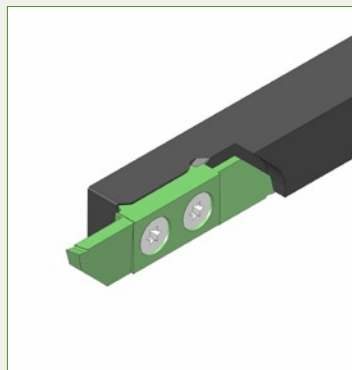
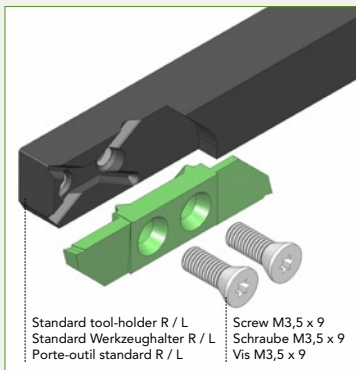

Maximum cutting-off  
Maximum Abstechen  
Tronçonnage maximum  
Ø 20 mm

Maximum turning  
Maximum Drehen  
Tournage maximum  
ap 6 mm

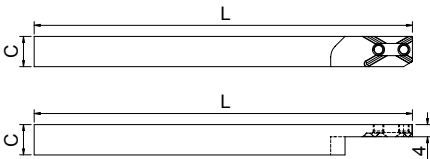

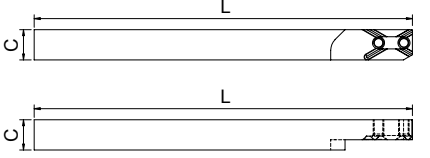
**Standard fixation**  
**Standard Befestigung**  
**Fixation standard**

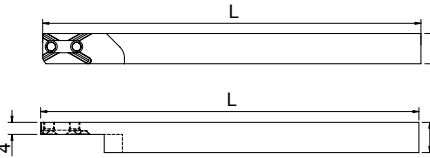
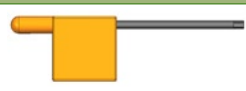

<b>10xxR</b>	Right tool-holder Werkzeughalter rechts Porte-outil à droite	Section C Querschnitt C Section C	Length L Länge L Longueur L	Article nr. Artikel Nr. N° Article
		10 x 10	124	1010R
		12 x 12	124	1012R
		14 x 14	124	1014R
		16 x 16	124	1016R
		20 x 20	124	1020R
<b>10xxR4</b>	Right «Pick-up» tool-holder «Pick-up» Werkzeughalter rechts Porte-outil «pick-up» à droite	Section C Querschnitt C Section C	Length L Länge L Longueur L	Article nr. Artikel Nr. N° Article
		10 x 10	124	1010R4
		12 x 12	124	1012R4
		16 x 16	124	1016R4
<b>10xxL</b>	Left tool-holder Werkzeughalter links Porte-outil à gauche	Section C Querschnitt C Section C	Length L Länge L Longueur L	Article nr. Artikel Nr. N° Article
		10 x 10	124	1010L
		12 x 12	124	1012L
		14 x 14	124	1014L
		16 x 16	124	1016L
		20 x 20	124	1020L
<b>10xxL4</b>	Left «Pick-up» tool-holder «Pick-up» Werkzeughalter links Porte-outil «pick-up» à gauche	Section C Querschnitt C Section C	Length L Länge L Longueur L	Article nr. Artikel Nr. N° Article
		10 x 10	124	1010L4
		12 x 12	124	1012L4
		16 x 16	124	1016L4
<b>100-1</b>	Key Schlüssel Clé	Article nr. Artikel Nr. N° Article		
	Torx 15	100-1		
<b>100-2</b>	Screw for standart tool-holder Schraube für standart Werkzeughalter Vis pour porte-outil standard	Article nr. Artikel Nr. N° Article		
	M3,5 x 9	100-2		

## By behind fixation Befestigung von hinten Fixation par l'arrière

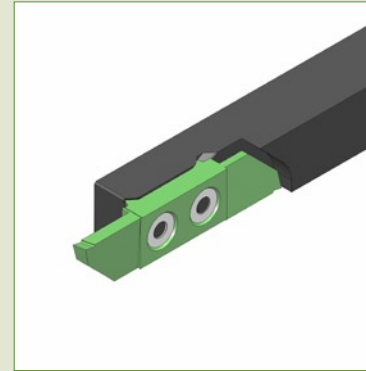
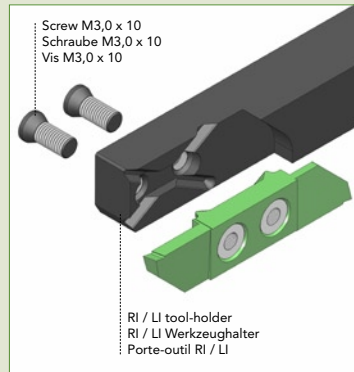
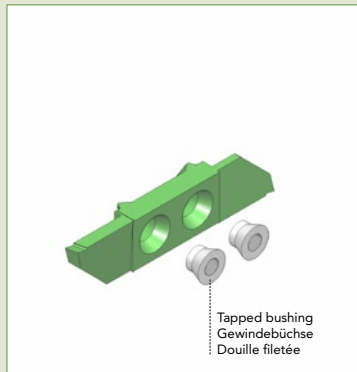

All inserts of OXOline 1000 (but not 1100) are available for «by behind fixation»: just add 2 tapped bushings (I-1000-M3) per insert on the order.

Alle wendepplatten von OXOline 1000 Linie (aber nicht 1100) sind verfügbar für die «Befestigung von hinten»: einfach 2 Gewindebüchsen (I-1000-M3,0) pro Wendepplatte zur Bestellung hinzufügen.

Toutes les plaquettes du programme OXOline 1000 (mais pas 1100) sont disponibles pour la «fixation par l'arrière»: simplement ajouter 2 douilles filetées (I-1000-M3,0) par plaquette sur la commande.

### Order Example :

1x 1010RI  
1x 1051RBI40  
2x I-1000-M3,0  
5x 1053RK10  
10x I-1000-M3,0

### Bestellung Beispiel :

1x 1010RI  
1x 1051RBI40  
2x I-1000-M3,0  
5x 1053RK10  
10x I-1000-M3,0

### Exemple de commande :

1x 1010RI  
1x 1051RBI40  
2x I-1000-M3,0  
5x 1053RK10  
10x I-1000-M3,0

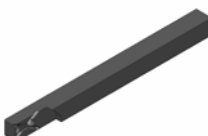
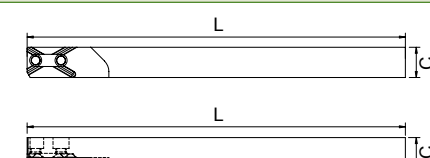
10xxRI	Right tool-holder for by behind fixation Werkzeughalter rechts für Befestigung von hinten Porte-outil droite pour fixation par l'arrière	Section C Querschnitt C Section C	Length L Länge L Longueur L	Article nr. Artikel Nr. N° Article
		10 x 10	124	1010RI
		12 x 12	124	1012RI
		16 x 16	124	1016RI

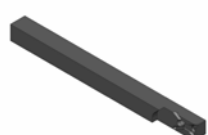
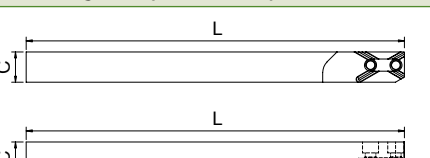
10xxLI	Left tool-holder for by behind fixation Werkzeughalter links für Befestigung von hinten Porte-outil gauche pour fixation par l'arrière	Section C Querschnitt C Section C	Length L Länge L Longueur L	Article nr. Artikel Nr. N° Article
		10 x 10	124	1010LI
		12 x 12	124	1012LI
		16 x 16	124	1016LI

100-3	Screw for «RI» and «LI» tool-holder Schraube für «RI» und «LI» Werkzeughalter Vis pour porte-outil «RI» et «LI»	Article nr. Artikel Nr. N° Article
	M3,0 x 10	100-3

I-1000-M3,0	Tapped bushing Gewindebüchse Douille fileté	Article nr. Artikel Nr. N° Article
	M3,0	I-1000-M3,0

Blank  
Rohling  
Ebauche

R : Right machining  
R : Rechts Bearbeitung  
R : Usinage à droite

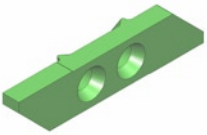
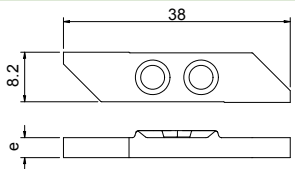
1040R	Blank insert Rohling Wendeplatte Plaquette ébauche	e	Article nr. Artikel Nr. N° Article	K10	B140	B140	TIN
		3,3	1040R3,3	✓	✓	◇	◇

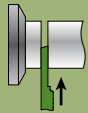

Cutting off  $\varnothing$  20 mm  
Abstechen  $\varnothing$  20 mm  
Tronçonnage  $\varnothing$  20 mm

R : Right machining  
R : Rechts Bearbeitung  
R : Usinage à droite

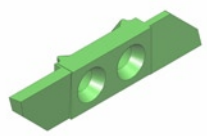
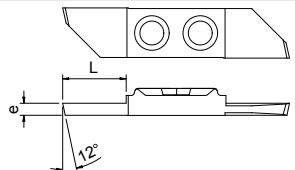
1050R	Cutting insert 12° Abstechplatte 12° Tronçonneur 12°	e	L	Article nr. Artikel Nr. N° Article	K10	B140	B140U	TIN
		1,0	5,0	1050R1,0	✓	✓	◇	◇
		1,2	6,0	1050R1,2	✓	✓	◇	◇
		1,5	7,5	1050R1,5	✓	✓	◇	◇
		2,0	10,5	1050R2,0	✓	✓	◇	◇
		2,5	10,5	1050R2,5	✓	✓	◇	◇

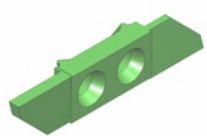
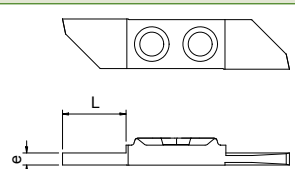
1050RP	Cutting insert 0° Abstechplatte 0° Tronçonneur 0°	e	L	Article nr. Artikel Nr. N° Article	K10	B140	B140U	TIN
		2,0	10,5	1050RP2,0	✓	✓	◇	◇
		2,5	10,5	1050RP2,5	✓	✓	◇	◇

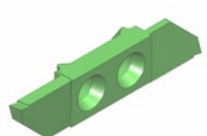
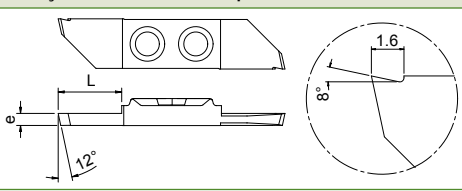
1051R	Cutting insert with chip breaker Abstechplatte mit Spanbrecher Tronçonneur avec brise-copeau	e	L	Article nr. Artikel Nr. N° Article	K10	B140	B140U	TIN
		2,0	10,5	1051R2,0	✓	✓	◇	◇
		2,5	10,5	1051R2,5	✓	✓	◇	◇

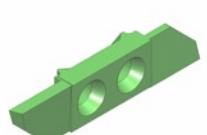
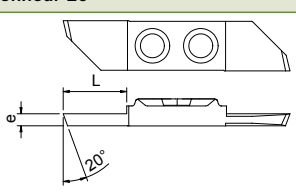
1052R	Cutting insert 20° Abstechplatte 20° Tronçonneur 20°	e	L	Article nr. Artikel Nr. N° Article	K10	B140	B140U	TIN
		1,5	7,5	1052R1,5	✓	✓	◇	◇
		2,0	10,5	1052R2,0	✓	✓	◇	◇
		2,5	10,5	1052R2,5	✓	✓	◇	◇

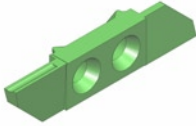
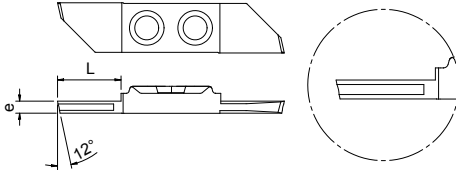

1054R	Cutting insert with chip roller Abstechplatte mit Spanroller Tronçonneur avec roule-copeau	e	L	Article nr. Artikel Nr. N° Article	K10	B140	B140U	TIN
					✓	✓	◇	◇
		1,5	7,5	1054R1,5	✓	✓	◇	◇
		2,0	10,5	1054R2,0	✓	✓	◇	◇
		2,5	10,5	1054R2,5	✓	✓	◇	◇

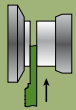

Opposite cutting off  $\varnothing$  20 mm  
 Umgekehrte Abstechen  $\varnothing$  20 mm  
 Tronçonnage inversé  $\varnothing$  20 mm

R : Right machining  
 R : Rechts Bearbeitung  
 R : Usinage à droite

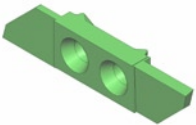
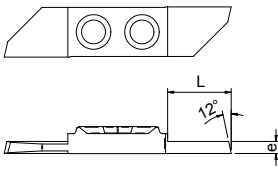
1053R	Opposite cutting insert Umgekehrte abstechplatte Tronçonneur inversé	e	L	Article nr. Artikel Nr. N° Article	K10	B140	B140U	TIN
					✓	✓	◇	◇
		1,0	6	1053R1,0	✓	✓	◇	◇
		1,2	6	1053R1,2	✓	✓	◇	◇
		1,5	7,5	1053R1,5	✓	✓	◇	◇
		2,0	10,5	1053R2,0	✓	✓	◇	◇
		2,5	10,5	1053R2,5	✓	✓	◇	◇

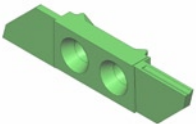
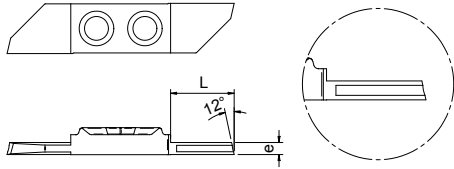
1053RX	Opposite cutting insert with chip roller Umgekehrte Abstechplatte mit Spanroller Tronçonneur inversé avec roule-copeau	e	L	Article nr. Artikel Nr. N° Article	K10	B140	B140U	TIN
					✓	✓	◇	◇
		1,5	7,5	1053RX1,5	✓	✓	◇	◇
		2,0	10,5	1053RX2,0	✓	✓	◇	◇

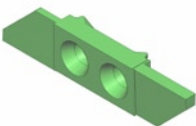
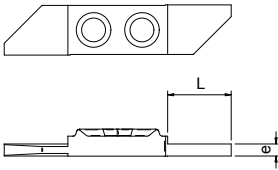
1053RP	Opposite cutting insert 0° Umgekehrte Abstechplatte 0° Tronçonneur inversé 0°	e	L	Article nr. Artikel Nr. N° Article	K10	B140	B140U	TIN
					✓	✓	◇	◇
		2,0	10,5	1053RP2,0	✓	✓	◇	◇
		2,5	10,5	1053RP2,5	✓	✓	◇	◇

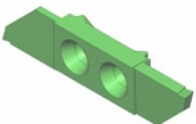
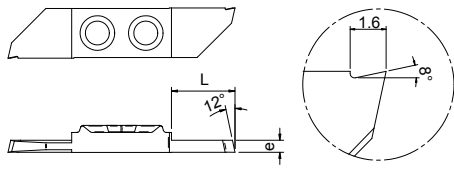
1056R	Opposite cutting insert with chip breaker Umgekehrte Abstechplatte mit Spanbrecher Tronçonneur inversé avec brise-copeau	e	L	Article nr. Artikel Nr. N° Article	K10	B140	B140U	TIN
					✓	✓	◇	◇
		1,5	7,5	1056R1,5	✓	✓	◇	◇
		2,0	10,5	1056R2,0	✓	✓	◇	◇
		2,5	10,5	1056R2,5	✓	✓	◇	◇

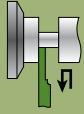

Back turning  
 Drehen hinten  
 Tournage arrière

R : Right machining  
 R : Rechts Bearbeitung  
 R : Usinage à droite

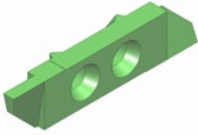
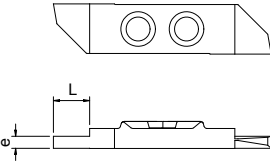
1060RP	Back turning insert 0° Drehplatte hinten 0° Tournage arrière 0°	e	L	Article nr. Artikel Nr. N° Article	K10	BI40	BI40U	TIN
		1,0	3	1060RP1,0	✓	✓	◇	◇
		1,5	4	1060RP1,5	✓	✓	◇	◇
		2,0	5	1060RP2,0	✓	✓	◇	◇
		2,5	6	1060RP2,5	✓	✓	◇	◇
		3,0	6	1060RP3,0	✓	✓	◇	◇

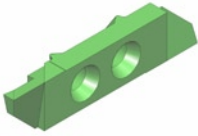
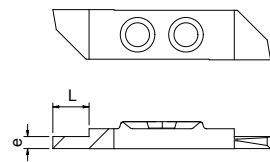
1061R	Back turning insert with «parisian cut» Drehplatte hinten mit «Pariserschliff» Tournage arrière avec «coupe parisienne»	e	L	Article nr. Artikel Nr. N° Article	K10	BI40	BI40U	TIN
		1,5	4	1061R1,5	✓	✓	◇	◇
		2,0	5	1061R2,0	✓	✓	◇	◇
		2,5	6	1061R2,5	✓	✓	◇	◇
		3,0	6	1061R3,0	✓	✓	◇	◇

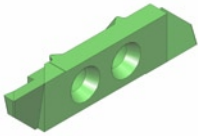
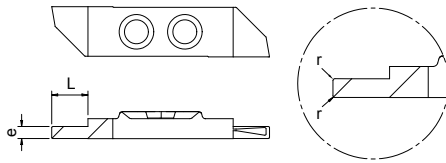
1061R - r	Back turning insert with «parisian cut» and radius Drehplatte hinten mit «Pariserschliff» und Radius Tournage arrière avec «coupe parisienne» et rayon	e	L	r	Article nr. Artikel Nr. N° Article	K10	BI40	BI40U	TIN
		1,5	4	0,1	1061R1,5 - r 0,1 -	✓	✓	◇	◇
		1,5	4	0,2	1061R1,5 - r 0,2 -	✓	✓	◇	◇
		2,0	5	0,1	1061R2,0 - r 0,1 -	✓	✓	◇	◇
		2,0	5	0,2	1061R2,0 - r 0,2 -	✓	✓	◇	◇
		2,5	6	0,1	1061R2,5 - r 0,1 -	✓	✓	◇	◇
		2,5	6	0,2	1061R2,5 - r 0,2 -	✓	✓	◇	◇
		3,0	6	0,2	1061R3,0 - r 0,2 -	✓	✓	◇	◇

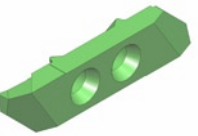
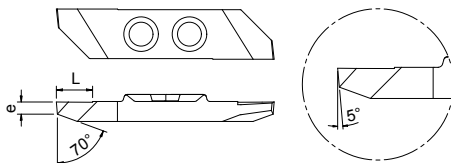
1062R	Back turning insert with «parisian cut» Drehplatte hinten mit «Pariserschliff» Tournage arrière avec «coupe parisienne»	e	L	Article nr. Artikel Nr. N° Article	K10	BI40	BI40U	TIN
		1,0	6	1062R1,0	✓	✓	◇	◇
		2,0	6	1062R2,0	✓	✓	◇	◇

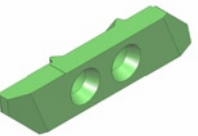
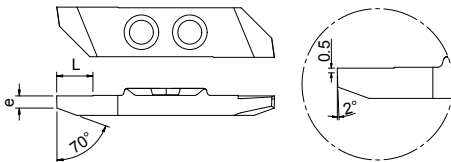
1062RO	Back turning insert Drehplatte hinten Tournage arrière	e	L	Article nr. Artikel Nr. N° Article	K10	BI40	BI40U	TIN
		1,0	5	1062RO1,0	✓	✓	◇	◇
		1,5	6	1062RO1,5	✓	✓	◇	◇

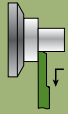

Front turning  
 Drehen vorne  
 Tournage avant

R : Right machining  
 R : Rechts Bearbeitung  
 R : Usinage à droite

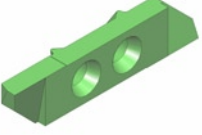
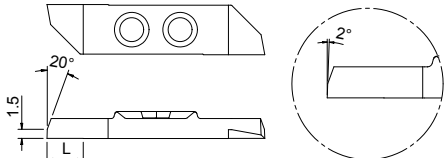
1064R	Front turning insert Drehplatte vorne Tourneur avant	L	Article nr. Artikel Nr. N° Article	K10	BI40	BI40U	TIN
		6	1064R	✓	✓	◇	◇

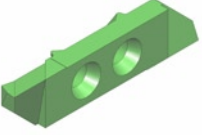
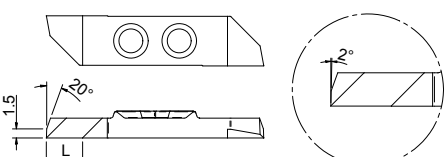
1065R	Front turning insert with chip breaker Drehplatte vorne mit Spannbrecher Tourneur avant avec brise-copeau	L	Article nr. Artikel Nr. N° Article	K10	BI40	BI40U	TIN
		6	1065R	✓	✓	◇	◇

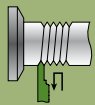

Threading  
 Gewindestrehlen  
 Filetage

R : Right machining  
 R : Rechts Bearbeitung  
 R : Usinage à droite

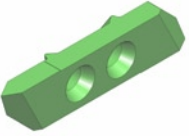
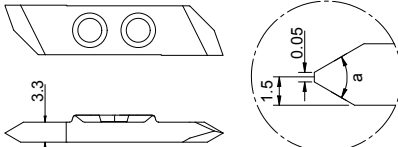
1080R	Threading insert with partial profile Gewindeplatte mit Partiielprofil Fileteur avec profil partiel	a	Article nr. Artikel Nr. N° Article	K10	BI40	BI40U	TIN
		55°	1080R - 55° -	✓	✓	◇	◇
		60°	1080R - 60° -	✓	✓	◇	◇

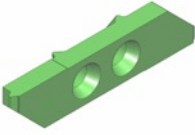
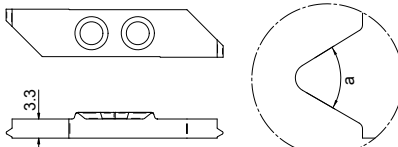
1081R	Threading insert with full profile Gewindeplatte mit Vollprofil Fileteur avec profil complet	a	Pitch Teilung pas	M	Article nr. Artikel Nr. N° Article	K10	BI40	BI40U	TIN
		60°	0,80	5	1081R0,8	✓	✓	◇	◇
		60°	1,00	6	1081R1,0	✓	✓	◇	◇
		60°	1,50	10	1081R1,5	✓	✓	◇	◇
		60°	1,75	12	1081R1,75	✓	✓	◇	◇
		60°	2,00	16	1081R2,0	✓	✓	◇	◇

Blank  
 Rohling  
 Ebauche

L : Left machining  
 L : Links Bearbeitung  
 L : Usinage à gauche

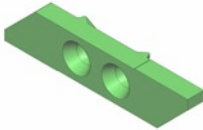
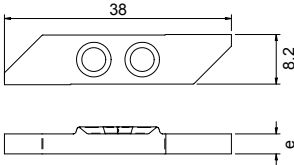
<b>1040L</b>	Blank insert Rohling Wendeplatte Plaquette ébauche	e	Article nr. Artikel Nr. N° Article	K10	B140	B140U	TIN
		3,3	1040L3,3	✓	✓	◇	◇

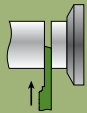

Cutting off  $\varnothing$  20 mm  
 Abstechen  $\varnothing$  20 mm  
 Tronçonnage  $\varnothing$  20 mm

L : Left machining  
 L : Links Bearbeitung  
 L : Usinage à gauche

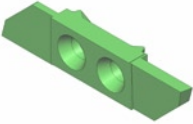
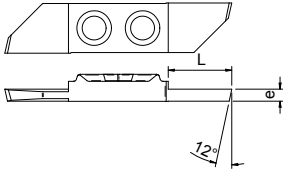
<b>1050L</b>	Cutting insert 12° Abstechplatte 12° Tronçonneur 12°	e	L	Article nr. Artikel Nr. N° Article	K10	B140	B140U	TIN
		1,0	6,0	1050L1,0	✓	✓	◇	◇
		1,5	7,5	1050L1,5	✓	✓	◇	◇
		2,0	10,5	1050L2,0	✓	✓	◇	◇
		2,5	10,5	1050L2,5	✓	✓	◇	◇
		3,0	10,5	1050L3,0	✓	✓	◇	◇

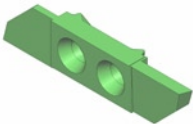
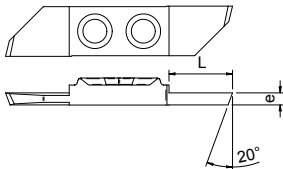
<b>1052L</b>	Cutting insert 20° Abstechplatte 20° Tronçonneur 20°	e	L	Article nr. Artikel Nr. N° Article	K10	B140	B140U	TIN
		1,5	7,5	1052L1,5	✓	✓	◇	◇
		2,0	10,5	1052L2,0	✓	✓	◇	◇
		2,5	10,5	1052L2,5	✓	✓	◇	◇

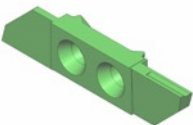
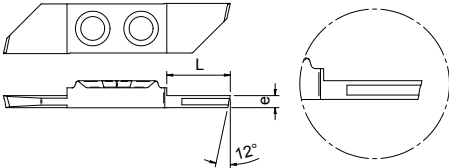
<b>1054L</b>	Cutting insert with chip roller Abstechplatte mit Spanroller Tronçonneur avec roule-copeau	e	L	Article nr. Artikel Nr. N° Article	K10	B140	B140U	TIN
		1,5	7,5	1054L1,5	✓	✓	◇	◇
		2,0	10,5	1054L2,0	✓	✓	◇	◇

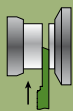

Opposite cutting off  $\varnothing$  20 mm  
 Umgekehrte Abstechen  $\varnothing$  20 mm  
 Tronçonnage inversé  $\varnothing$  20 mm

L : Left machining  
 L : Links Bearbeitung  
 L : Usinage à gauche

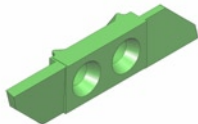
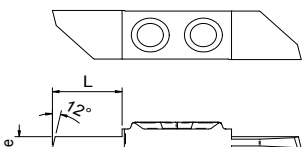
<b>1053L</b>	Opposite cutting insert Umgekehrte Abstechplatte Tronçonneur inversé	e	L	Article nr. Artikel Nr. N° Article	K10	B140	B140U	TIN
		1,5	7,5	1053L1,5	✓	✓	◇	◇
		2,0	10,5	1053L2,0	✓	✓	◇	◇

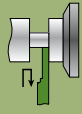

Back turning  
 Drehen hinten  
 Tournage arrière

L : Left machining  
 L : Links Bearbeitung  
 L : Usinage à gauche

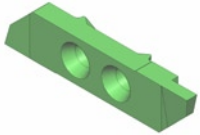
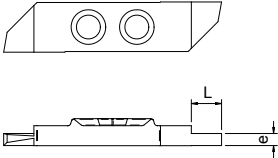
1060LP	Back turning insert 0° Drehplatte hinten 0° Tourneur arrière 0°	e	L	Article nr. Artikel Nr. N° Article	K10	B140	B140U	TIN
		2,0	5	1060LP2,0	✓	✓	◇	◇
		2,5	6	1060LP2,5	✓	✓	◇	◇
		3,0	6	1060LP3,0	✓	✓	◇	◇

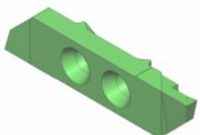
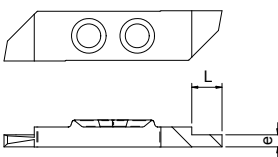
1061L	Back turning insert with «parisian cut» Drehplatte hinten mit «Pariserschliff» Tourneur arrière avec «coupe parisienne»	e	L	Article nr. Artikel Nr. N° Article	K10	B140	B140U	TIN
		1,0	3	1061L1,0	✓	✓	◇	◇
		1,5	4	1061L1,5	✓	✓	◇	◇
		1,8	4	1061L1,8	✓	✓	◇	◇
		2,0	5	1061L2,0	✓	✓	◇	◇
		2,5	6	1061L2,5	✓	✓	◇	◇
		3,0	6	1061L3,0	✓	✓	◇	◇

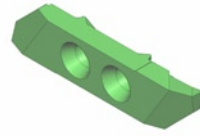
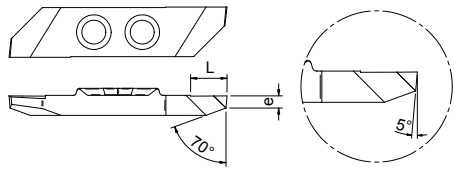
1062L	Back turning insert with «parisian cut» Drehplatte hinten mit «Pariserschliff» Tourneur arrière avec «coupe parisienne»	e	L	Article nr. Artikel Nr. N° Article	K10	B140	B140U	TIN
		1,0	6	1062L1,0	✓	✓	◇	◇
		1,5	6	1062L1,5	✓	✓	◇	◇

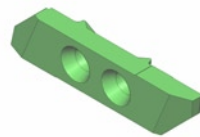
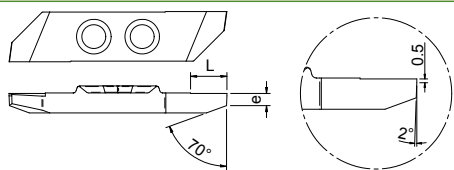
1062LO	Back turning insert Drehplatte hinten Tourneur arrière	e	L	Article nr. Artikel Nr. N° Article	K10	B140	B140U	TIN
		1,0	5	1062LO1,0	✓	✓	◇	◇
		1,5	6	1062LO1,5	✓	✓	◇	◇
		2,0	6	1062LO2,0	✓	✓	◇	◇

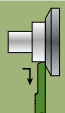

Front turning  
 Drehen vorne  
 Tournage avant

L : Left machining  
 L : Links Bearbeitung  
 L : Usinage à gauche

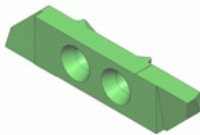
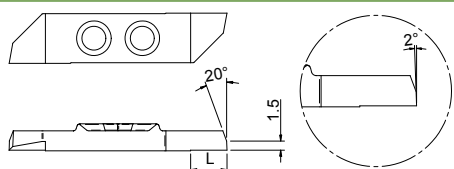
1064L	Front turning insert Drehplatte vorne Tourneur avant	L	Article nr. Artikel Nr. N° Article	K10	B140	B140U	TIN
		6	1064L	✓	✓	◇	◇

**Field of application of OXOline 1100**  
**Anwendungsbereich von OXOline 1100**  
**Champ d'application d'OXOline 1100**

Maximum cutting-off  
 Maximum Abstechen  
 Tronçonnage maximum  
 Ø 32 mm

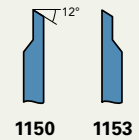
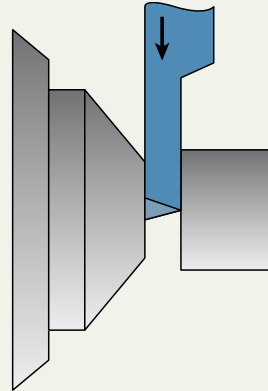

Cutting off  
 Abstechen  
 Tronçonnage

**Standard fixation**  
**Standard Befestigung**  
**Fixation standard**

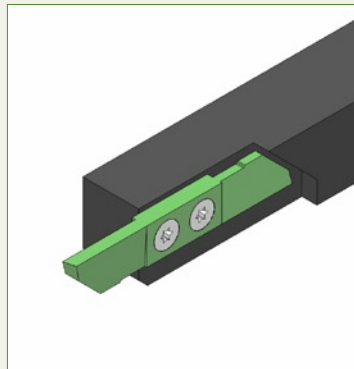
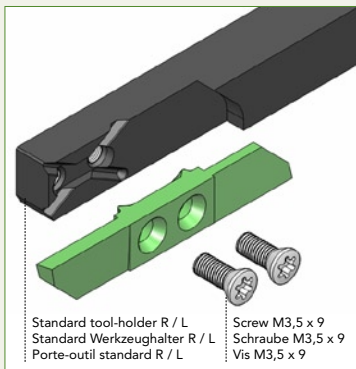

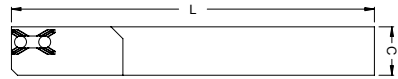
11xxR	Right tool-holder Werkzeughalter rechts Porte-outil à droite	Section C Querschnitt C Section C	Length L Länge L Longueur L	Article nr. Artikel Nr. N° Article
		10 x 10	124	1110R
		12 x 12	124	1112R
		16 x 16	124	1116R
		20 x 20	124	1120R

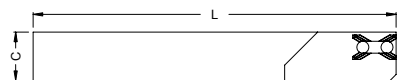
11xxL	Left tool-holder Werkzeughalter links Porte-outil à gauche	Section C Querschnitt C Section C	Length L Länge L Longueur L	Article nr. Artikel Nr. N° Article
		10 x 10	124	1110L
		12 x 12	124	1112L
		16 x 16	124	1116L
		20 x 20	124	1120L

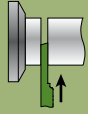

Cutting off  $\varnothing$  32 mm  
 Abstechen  $\varnothing$  32 mm  
 Tronçonnage  $\varnothing$  32 mm

R : Right machining  
 R : Rechts Bearbeitung  
 R : Usinage à droite

1150R	Cutting insert 15° Abstechplatte 15° Tronçonneur 15°	e	L	Article nr. Artikel Nr. N° Article	K10	B140	B140U	TIN
		2,5	17	1150R2,5	✓	✗	✓	◇
		3,0	17	1150R3,0	✓	✗	✓	◇

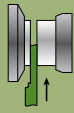

Opposite cutting off  $\varnothing$  32 mm  
 Umgekehrte Abstechen  $\varnothing$  32 mm  
 Tronçonnage inversé  $\varnothing$  32 mm

R : Right machining  
 R : Rechts Bearbeitung  
 R : Usinage à droite

1153R	Opposite cutting insert 15° Umgekehrte Abstechplatte 15° Tronçonneur inversé 15°	e	L	Article nr. Artikel Nr. N° Article	K10	B140	B140U	TIN
		2,5	17	1153R2,5	✓	✗	✓	◇
		3,0	17	1153R3,0	✓	✗	✓	◇

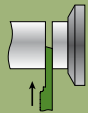

Cutting off  $\varnothing$  32 mm  
 Abstechen  $\varnothing$  32 mm  
 Tronçonnage  $\varnothing$  32 mm

L : Left machining  
 L : Links Bearbeitung  
 L : Usinage à gauche

1150L	Cutting insert 15° Abstechplatte 15° Tronçonneur 15°	e	L	Article nr. Artikel Nr. N° Article	K10	B140	B140U	TIN
		2,5	17	1150L2,5	✓	✗	✓	◇
		3,0	17	1150L3,0	✓	✗	✓	◇

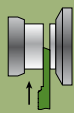

Opposite cutting off  $\varnothing$  32 mm  
 Umgekehrte Abstechen  $\varnothing$  32 mm  
 Tronçonnage inversé  $\varnothing$  32 mm

L : Left machining  
 L : Links Bearbeitung  
 L : Usinage à gauche

1153L	Opposite cutting insert 15° Umgekehrte Abstechplatte 15° Tronçonneur inversé 15°	e	L	Article nr. Artikel Nr. N° Article	K10	B140	B140U	TIN
		2,5	17	1153L2,5	✓	✗	✓	◇
		3,0	17	1153L3,0	✓	✗	✓	◇